

WORK AREA

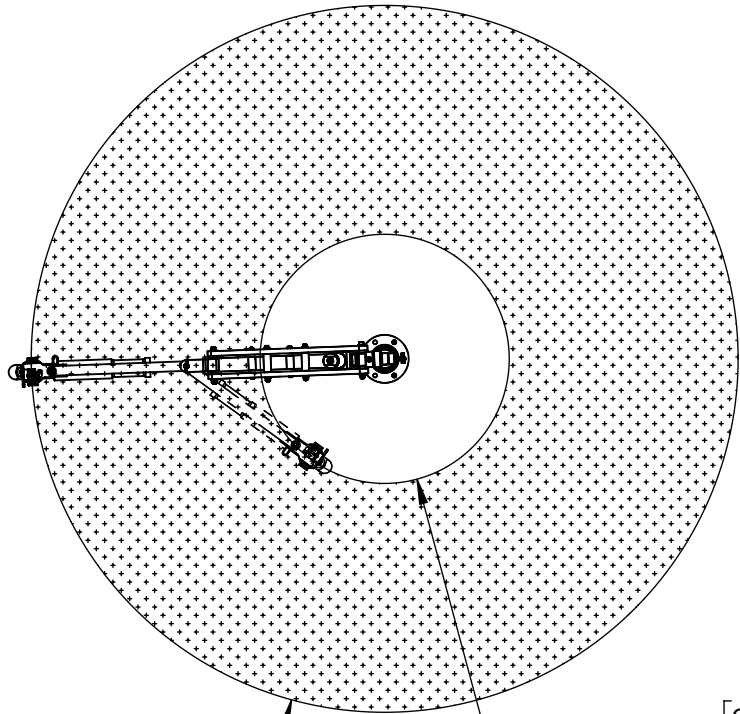

[1932mm]  
Ø76in

MIN. REACH  
[659mm]  
Ø26in

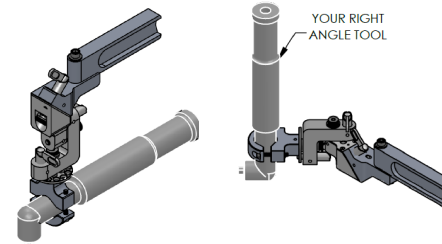

SEE PAGE 2 FOR  
TOOL-HOLDER  
DETAILS

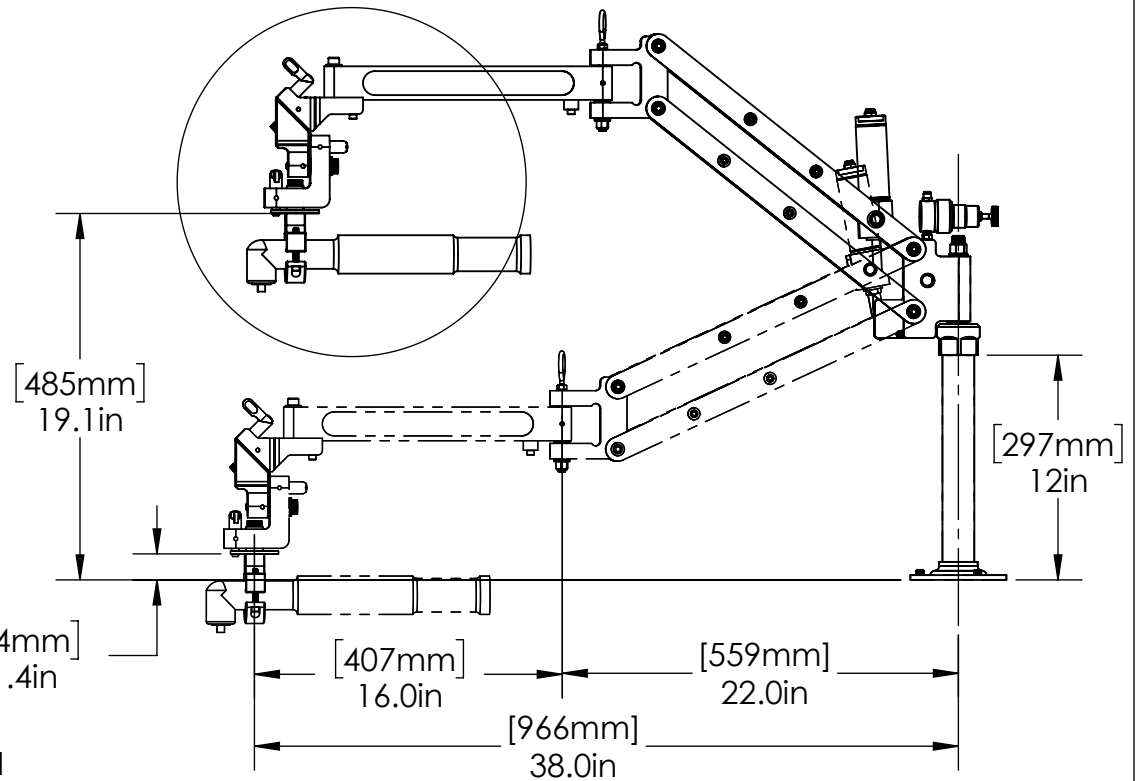

MODEL#: EL1015-RAHV

TOOL-HOLDER INCLUDED: RAHV-TH

Extra Heavy Duty Arm with tool holder that locks in both HORIZONTAL and VERTICAL orientation with customer's Right Angle DC Tool.

MAX HORZ. TORQUE: 600 in-lbs (68 Nm)

MAX VERT. TORQUE: 800 in-lbs (90 Nm)

MAX. TOOLING WEIGHT: 10 lbs (4.5 Kg)

COPYRIGHT © 2018 ERGONOMIC TOOL ARMS, LLC

www.toolarms.com



Ergonomic Tool Arms, LLC

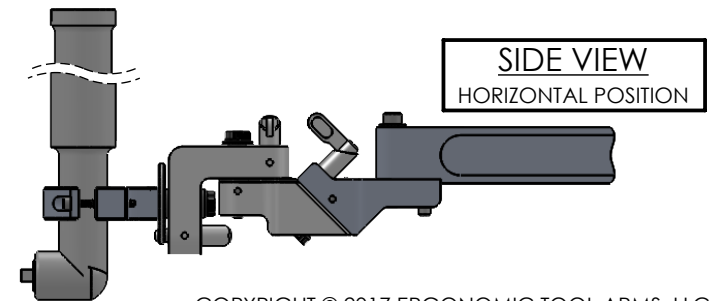
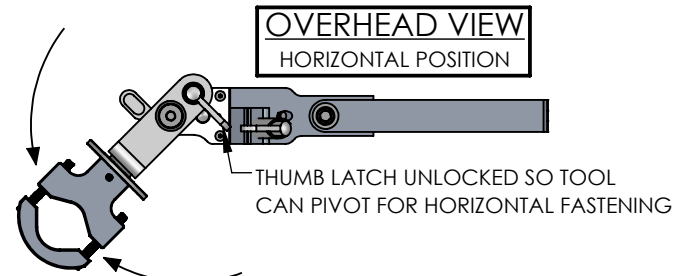
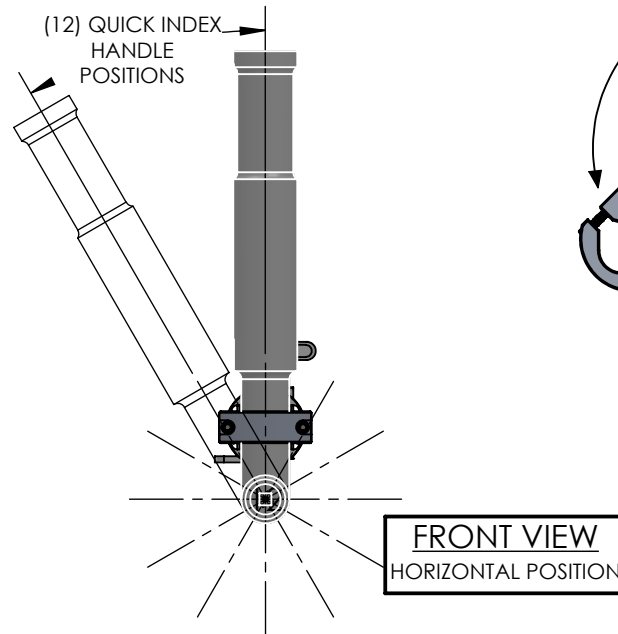
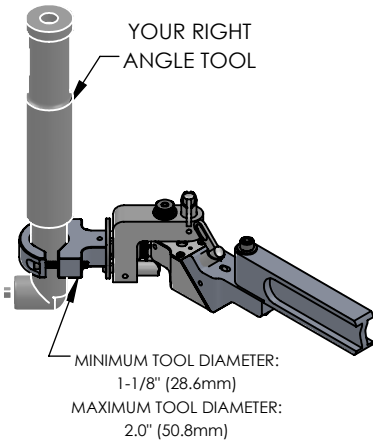
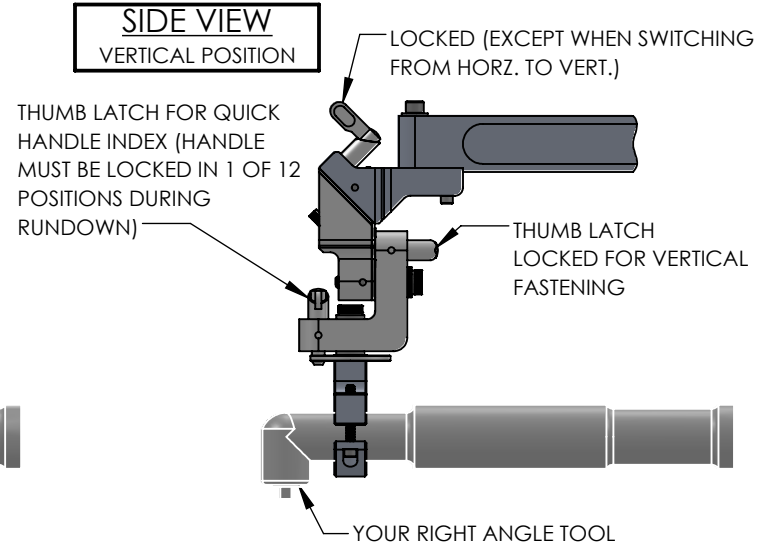
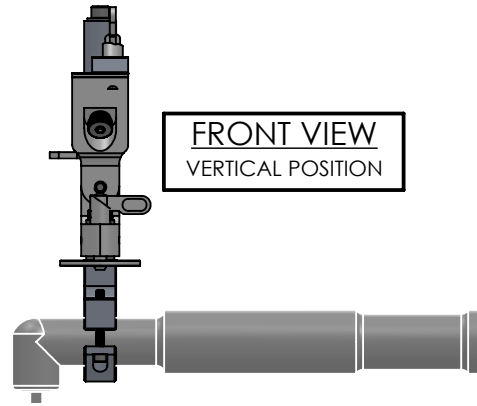
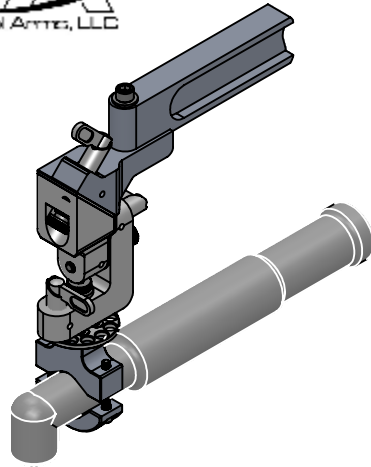

COPYRIGHT © 2017 ERGONOMIC TOOL ARMS, LLC

Model **RAHV-TH**  
**Right Angle Horizontal & Vertical Tool Holder**  
FOR HORIZONTAL & VERTICAL FASTENING

THIS DRAWING CONTAINS CONFIDENTIAL INFORMATION, IS THE PROPERTY OF ERGONOMIC TOOL ARMS, LLC AND IS GIVEN TO THE RECEIVER IN CONFIDENCE. THE RECEIVER BY RECEPTION AND RETENTION OF THIS DRAWING, ACCEPTS THE DRAWING IN CONFIDENCE AND AGREES THAT IT WILL NOT USE THE DRAWING OR A COPY THEREOF OR THE CONFIDENTIAL INFORMATION IT CONTAINS FOR THE PURPOSES OTHER THAN THAT INSTRUCTED BY ERGONOMIC TOOL ARMS, LLC, EITHER WRITTEN OR IMPLIED. THE RECEIVER AGREES, BY ACCEPTANCE AND RETENTION TO BE HELD LIABLE FOR MISUSE OF THIS DRAWING OR THE INFORMATION IT CONTAINS.